



**ELEFLEX**

# **FRENI ELETTROMAGNETICI ELECTROMAGNETIC BRAKES**





## Soluzioni innovative integrate

Dal 1974 progettiamo e produciamo equipaggiamenti per l'automazione di processo nella lavorazione di laminati, in particolare per i settori del converting, della carta e del cartone, del filo metallico, della lavorazione della gomma e della plastica, del tessile, del tessuto non tessuto.

## Integrated innovative solutions

*We have been designing and manufacturing laminate machining process automation equipment, mainly for the converting, paper and cardboard, metal wire, and rubber, plastic, textile and non-woven fabrics processing sectors since 1974.*

**Re S.p.A.**  
Via Firenze 3  
20060 Bussero (MI) Italy

**T** +39 02 9524301  
**F** +39 02 95038986  
**E** info@re-spa.com

Ufficio commerciale Italia  
Domestic sales Dpt.  
**E** sales-it@re-spa.com

Ufficio commerciale estero  
Export sales Dpt.  
**E** sales-ex@re-spa.com

Ufficio tecnico  
Technical Dpt.  
**E** technical@re-spa.com

Assistenza tecnica  
Customer care service  
**E** support@re-spa.com



Dal 2001 membri di ACIMGA  
Since 2001 member of ACIMGA



Progettiamo e produciamo per un futuro migliore e più pulito  
We have been designing and manufacturing for a better and cleaner future

**m a d e i n I t a l y**



## ELEFLEX FRENI ELETTROMAGNETICI ELECTROMAGNETIC BRAKES



### La serie ELEFLEX

La serie ELEFLEX di freni e frizioni a polvere elettromagnetica è uno dei nostri più collaudati prodotti che produciamo da oltre 20 anni.

L'esperienza maturata con **migliaia di applicazioni** in svariati settori, la ricerca di materiali innovativi e il continuo studio del comportamento di questi freni ci hanno permesso di accrescere il nostro know-how apportando continue migliorie al nostro prodotto.

La gamma ELEFLEX di freni e frizioni garantisce:

- **alta precisione** nel controllo della coppia,
- compattezza,
- **nessuna emissione** di materiale inquinante,
- **coppia residua ridotta**.



Plastic film



Food packaging

Particolarmente indicati nel settore della stampa, su macchine flessografiche e rotocalco, trovano ampio uso anche in ambienti alimentari o particolarmente esigenti in quanto a pulizia ed emissione di polveri, come le camere bianche. Ideali nel settore food-packaging, su macchine laminatrici o per il film plastico, ed in tutte quelle applicazioni con tiri molto bassi grazie alle ridottissime coppie residue.

Una rete capillare di distributori in tutto il mondo vi garantisce un servizio post-vendita ed un'assistenza tecnica altamente specializzata entro poche ore dalla chiamata.

### The ELEFLEX range

The ELEFLEX range of electromagnetic powder brakes and clutches is one of our most tried and tested products, and has been in production for over 20 years.

This wealth of experience, covering thousands of applications in a various sectors, the research into innovative materials and the continuous studies carried out into how these brakes perform have permitted us to acquire extensive know-how, and continually improve our product.

ELEFLEX range of brakes and clutches features:

- **high precision** torque control,
- small size,
- **no pollutants** produced,
- **reduced residual torque**.

For these reasons, they are particularly suitable for use in the printing sector, flexographic and rotogravure machines, but also in food preparation areas or locations with stringent hygiene and dust emission tolerances, such as in clean rooms. They are ideal for use in the food-packaging sector, on laminating or plastic film machines and all applications involving low web tension, thanks to their very low residual torque.

Our world-wide distributor network guarantees that you receive highly specialised post-sales service and technical assistance within a few hours of your call.

I dati del presente catalogo sono ritenuti corretti al momento della loro pubblicazione, ciò non implica responsabilità da parte della Re Spa per eventuali variazioni intervenute successivamente.

This catalogue information is correct at date of publication, but is subject to change without prior notification, or as required by Re Spa.





## Principio di funzionamento

Il freno a polvere elettromagnetica è costituito da tre parti fondamentali: **una bobina, uno statore ed un rotore**. Fornendo corrente al freno, all'interno della bobina si avrà una variazione del campo magnetico proporzionale all'intensità di corrente stessa. La variazione del campo magnetico modifica la viscosità della speciale polvere situata tra il rotore e lo statore.



Quando la bobina viene eccitata elettricamente le particelle si orientano in base alle linee di forza del campo magnetico determinando un legame di trascinamento tra il rotore e lo statore e permettendo così la frenatura.

When an electrical current is applied to the coil, the particles are aligned along the magnetic field force lines, creating a dragging bond between the rotor and the stator, thereby generating the braking effect.

## Operating principle

The electromagnetic powder brake consists of three basic components: **a coil, a stator and a rotor**. When current is supplied to the brake, the magnetic field inside the coil starts to vary in proportion to the size of the current. The variations in the magnetic field alter the viscosity of the special powder positioned between the rotor and the stator.



Quando viene tolta la corrente la polvere viene schiacciata contro lo statore dalla forza centrifuga lasciando così il rotore libero di ruotare.

When the current is disconnected, the powder is pushed against the stator by the centrifugal force, thus releasing the rotor so that it can rotate.

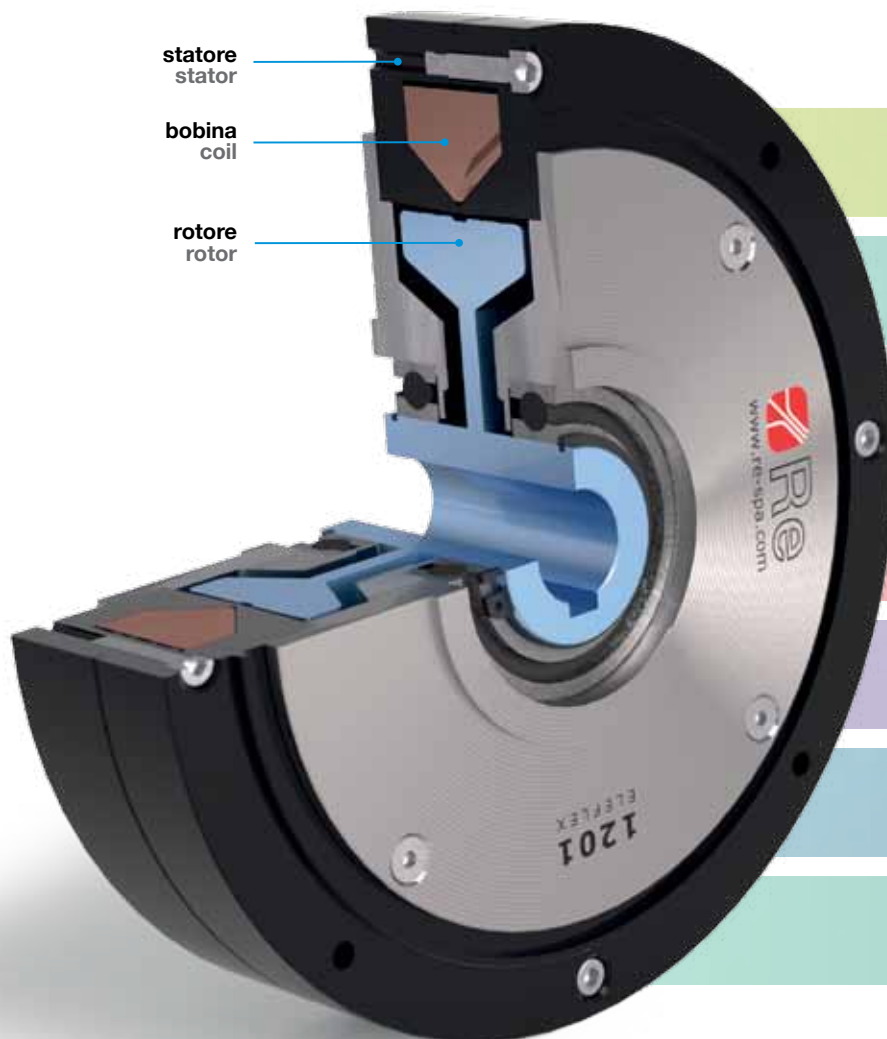



## Caratteristiche operative

Dalla continua ricerca di nuove soluzioni che possano migliorare le prestazioni dei nostri prodotti è nata una nuova generazione di freni ELEFLEX.

La nuova ingegnerizzazione dei già ampiamente collaudati freni a polvere Re, presenta un particolare sistema in grado di abbattere il magnetismo residuo e l'attrito meccanico, portando la coppia residua a meno dell'1% di quella nominale.

La coppia dei nuovi freni è indipendente dalla velocità di scorrimento del rotore (entro la gamma di funzionamento raccomandata dai 40 ai 2000 RPM), e può subire un'oscillazione massima del 5% in presenza di costante intensità di corrente.

## Operating characteristics

From the constant research of new solutions to improve our products' performances is born a new generation of ELEFLEX brakes.

The new engineering of this widely tried and tested range of Re's electromagnetic powder brakes, has a special design that lowered the iron circuit residual magnetism and the mechanical friction, bringing down the residual torque to less than 1% of the nominal torque.

The torque of these new brakes is independent of rotor speed (within the recommended operating range from 40 to 2000 RPM) and it can vary by 5% keeping constant current supply.

**nuova ingegnerizzazione**  
*new engineering*

**abbattimento del magnetismo residuo**  
*lowering of the iron circuit residual magnetism*

**abbattimento dell'attrito meccanico**  
*lowering of the mechanical friction*

**<1%** coppia residua inferiore  
*residual torque less than*

**5%** max oscillazione della coppia  
*max torque variation*

**40-2000RPM** gamma di funzionamento raccomandata  
*recommended operating range*

**coppia indipendente dalla velocità**  
*torque independent of (rotor) speed*



## La gamma Eleflex

La gamma dei freni a polvere parte dai piccolissimi B.20 con 2 Nm di coppia fino ai B.5000 da 500 Nm, con la possibilità di incrementare la dissipazione del calore attraverso l'ausilio di anelli radianti o ventilatore, aumentando così la vita utile del freno.

## The Eleflex range

The powder brakes range from the tiny B.20 that produces 2 Nm of torque, up to the B.5000 that generates 500 Nm, and can be fitted with additional heat dissipation devices, such as ring heat-sinks or fans, in order to prolong the life of the brake.



freno  
brake



freno con ventilatore  
brake with fan



freno con radiatore  
brake with radiator



frizione con radiatore  
clutch with radiator



## Applicazioni speciali

I nostri uffici tecnici sono sempre a disposizione della clientela per collaborare insieme allo sviluppo di nuove soluzioni, personalizzate in base alle loro esigenze. Sono già state progettate per alcuni clienti soluzioni speciali, tra cui:

- freni e frizioni in grado di lavorare a bassissime velocità (fino a 10 RPM) o altissime velocità (superiori a 2000 RPM),
- freni con ventilazione potenziata (1),
- freni speciali per applicazioni con asse verticale (2).

## Special applications

Our technical department is available to discuss any special applications, working together to achieve our customers needs. We already designed special solutions for some customers, as for example:

- brakes and clutches working at lower speeds (as low as 10 RPM) or at higher speed (more than 2000 RPM),
- brakes with high performance cooling fans (1),
- special brakes and clutches for vertically mounted applications (2).

1













2



# FRENI ELETTROMAGNETICI ELECTROMAGNETIC BRAKES



		Coppia nominale Nm Torque Nm	Coppia residua Nm Residual torque Nm	Corrente A Current A	Resistenza Ohm Resistance Ohm	Tensione V Voltage V	Potenza dissipabile W Power dissipation W
<b>B freno /brake</b> <b>C frizione /clutch</b>							
<b>B.20</b>		2	0,07	1	24	24	24
<b>B.53</b>		5	0,03	1	24	24	70
<b>B.55</b>		5	0,04	1	24	24	75
<b>B.121</b> <b>C.121</b>		12	0,06	1	24	24	80
<b>B.351</b> <b>C.351</b>		35	0,2	1	24	24	130
<b>B.651</b> <b>C.651</b>		65	0,4	1	24	24	170
<b>B.1201</b> <b>C.1201</b>		120	0,5	1	24	24	330
<b>B.1701</b> <b>C.1701</b>		170	0,5	1	24	24	450
<b>B.2500</b> <b>C.2500</b>		250	3	0,94	25,5	24	500
<b>B.5000</b> <b>C.5000</b>		500	6	0,94	25,5	24	1300

## ► Simboli e unità di misura / Symbols and units of measure

Coppia dinamica massima/minima	<b>Cd<sub>max</sub> / Cd<sub>min</sub> [Nm]</b>	Maximum/minimum dynamic torque
Inerzia	<b>J [Kgm<sup>2</sup>]</b>	Total inertia load
Numero di giri	<b>n [rpm]</b>	Rounds per minutes
Numero di giri minimo	<b>n<sub>min</sub> [rpm]</b>	Minimum rounds per minutes
Tempo di frenatura	<b>t [s]</b>	Braking time
Velocità lineare	<b>v [m/min]</b>	Web speed
Tensione massima/minima sul materiale	<b>T<sub>max</sub> / T<sub>min</sub> [N]</b>	Maximum/minimum web tension
Diametro massimo/minimo bobina	<b>D<sub>max</sub> / D<sub>min</sub> [m]</b>	Maximum/minimum roll diameter
Potenza dissipata in calore in continuo	<b>Pc [W]</b>	Continuous mean power
Peso massimo bobina	<b>m [kg]</b>	Roll maximum weight
Raggio massimo bobina	<b>r [m]</b>	Roll maximum radius
Tensione sul materiale per centimetro	<b>Ts [N/cm]</b>	Web tension per centimeter
Larghezza materiale massima/minima	<b>Lg<sub>max</sub> / Lg<sub>min</sub> [cm]</b>	Maximum/minimum web width

## ► Guida alla scelta del freno/frizione / Guide for brake/clutch selection

### ► Valori di tensione consigliati per singolo materiale Sefic tension values for typical converting materials

#### Carta / Paper

Peso g/m <sup>2</sup> / Weight g/m <sup>2</sup>	10	30	60	100	150	200
Tensione per centimetro Ts N/cm / Web tension per centimeter Ts N/cm	0,3	1	2,5	3,2	4	4,8

**Cellophane** (N/cm per  $\mu$  di spessore)  
Cellophane (N/cm for  $\mu$  of thickness) 0,042

**Polietilene** (N/cm per  $\mu$  di spessore)  
Polyethylene (N/cm for  $\mu$  of thickness) 0,02

**Polipropilene orientato** (N/cm per  $\mu$  di spessore)  
Polypropylene oriented (N/cm for  $\mu$  of thickness) 0,025

**Alluminio in foglia ricotto** (N/cm per  $\mu$  di spessore)  
Aluminium foil (N/cm for  $\mu$  of thickness) 0,025





## Formule utili Useful formulas

$$J = \frac{m \cdot r^2}{2} = \text{Kgm}^2$$

Inerzia bobina  
Roll inertia

$$n = \frac{v}{\pi \cdot D_{\max/\min}} = \text{rpm}$$

Numero di giri minimo/massimo  
Minimum/maximum revolutions per minute

$$v = \pi \cdot D \cdot n = \text{m/min}$$

Velocità lineare  
Web speed

## Slittamento continuo Tensioning

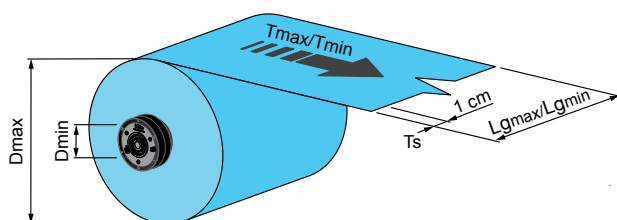

## Esempio di calcolo Calculation example

Nastro di polipropilene orientato - spess. 40 μ  
Polypropylene oriented foil - thickness 40 μ

<b>D<sub>max</sub></b>	= 0,8 m	<b>D<sub>min</sub></b>	= 0,1 m
<b>L<sub>gmax</sub></b>	= 120 cm	<b>L<sub>gmin</sub></b>	= 40 cm
<b>v</b>	= 180 m/min	<b>m</b>	= 700 kg

$$T_{\max} = T_s \cdot L_{g\max}$$

Tensione massima sul materiale  
Maximum web tension

$$T_{\max} = (0,025 \text{ N/cm} \cdot 40 \mu) \cdot 120 \text{ cm} = 120 \text{ N}$$

$$T_{\min} = T_s \cdot L_{g\min}$$

Tensione minima sul materiale  
Minimum web tension

$$T_{\min} = 1 \text{ N/cm} \cdot 40 \text{ cm} = 40 \text{ N}$$

$$C_{d\max} = \frac{D_{\max} \cdot T_{\max}}{2}$$

Coppia dinamica massima  
Maximum dynamic torque

$$C_{d\max} = \frac{0,8 \text{ m} \cdot 120 \text{ N}}{2} = 48 \text{ Nm}$$

$$C_{d\min} = \frac{D_{\min} \cdot T_{\min}}{2}$$

Coppia dinamica minima  
Minimum dynamic torque

$$C_{d\min} = \frac{0,1 \text{ m} \cdot 40 \text{ N}}{2} = 2 \text{ Nm}$$

$$P_c = \frac{T_{\max} \cdot v}{60}$$

Pot. dissipata in calore in continuo  
Continuous mean power

$$P_c = \frac{120 \text{ N} \cdot 180 \text{ m/min}}{60} = 360 \text{ W}$$

$$n_{\min} = \frac{v}{D_{\max} \cdot \pi}$$

Numero di giri minimo  
Minimum average rounds per minutes

$$n_{\min} = \frac{180 \text{ m/min}}{0,8 \text{ m} \cdot \pi} = 72 \text{ rpm}$$

## Frenatura d'emergenza Emergency stop

$$C_{d\max} = \frac{m \cdot D_{\max} \cdot v}{240 \cdot t} = \text{Nm}$$

Coppia dinamica  
Dynamic torque

## Esempio di calcolo Calculation example

$$t = 8 \text{ s}$$

$$C_{d\max} = \frac{700 \text{ kg} \cdot 0,8 \text{ m} \cdot 180 \text{ m/min}}{240 \cdot 8 \text{ s}} = 52,5 \text{ Nm}$$

Freno consigliato / Recommended brake:  
**B.651.V**



## Modelli mini

Questi modelli sono utilizzati prevalentemente nel settore tessile e nella lavorazione del filo metallico, dove sono necessarie applicazioni con tiri molto bassi e un accurato controllo della tensione del materiale.

I nostri uffici tecnici sono a disposizione del cliente per studiare l'applicazione più corretta in base al tipo di esigenza, integrando eventualmente un radiatore o un ventilatore, o progettando un nuovo modello di freno-frizione mini.



**Textile** **Metal-wire**

## Mini models

These models are mainly used in the textile and metal wire sectors where applications providing low web tension and precise control of the tension applied to the material are essential.

Our technical offices are able to provide customers with applications that satisfy their specific requirements, including brakes fitted with radiators or fans, or design special miniature clutch or brake models.



**B.53**

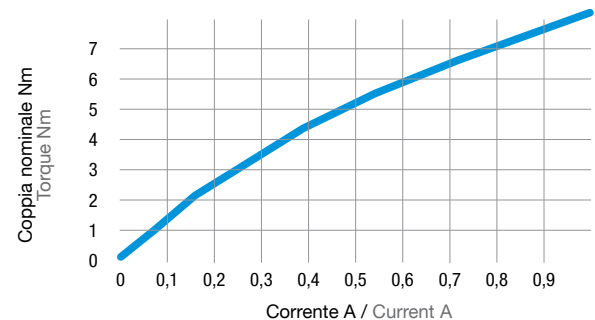
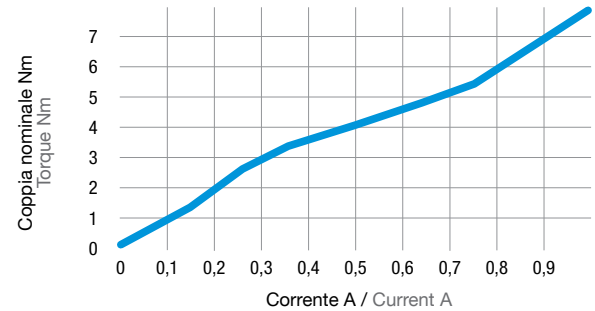
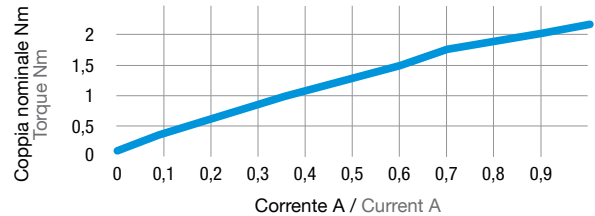



## B.20

N°3 fori per viti M4 per fissaggio macchina  
No. 3 threaded holes M4 for fastening

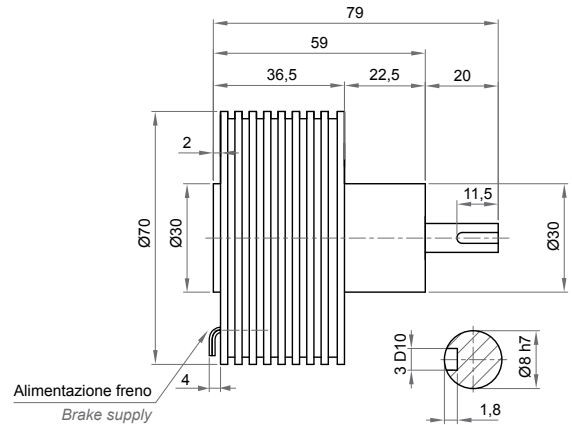
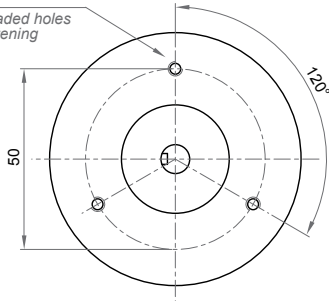

## B.53

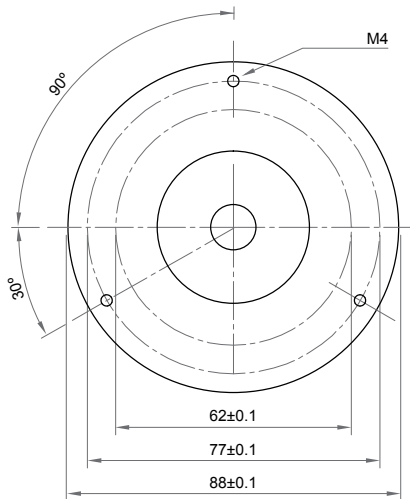

N°3 lamature per viti da M4 per fissaggio macchina.  
ATTENZIONE: prima di inserire la vite rimuovere il filetto con una punta Ø 4,5

3 counterbores for M4 screws for fastening.  
ATTENTION: before inserting the screw remove the thread with a drill Ø 4,5

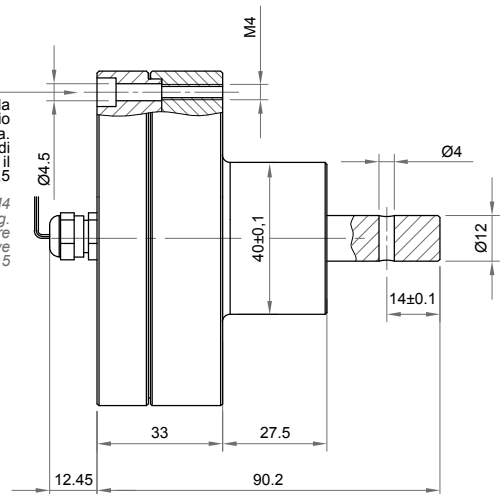

## B.55

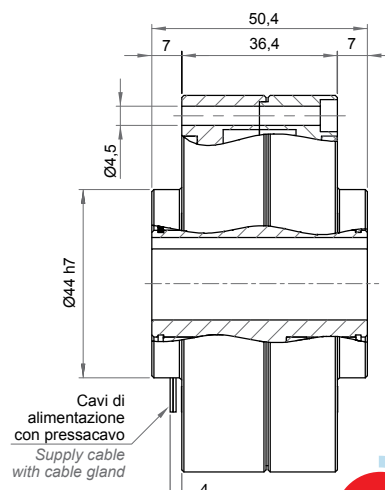
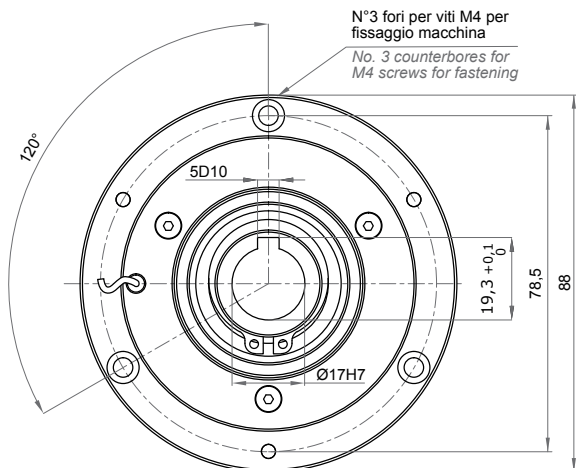

	B.20	B.53	B.55	
Coppia nominale Nm	2	5	5	Torque Nm
Coppia residua Nm	0,07	0,03	0,04	Residual torque Nm
Corrente massima A	1	1	1	Max current A
Resistenza a 20°C Ohm	24	24	24	Resistance at 20°C Ohm
Tensione V (PWM)	24	24	24	Voltage V (PWM)
Potenza dissipabile W	24	70	75	Power dissipation W
Rpm min/max	40-2000	40-2000	40-2000	Rpm min/max
Peso kg	0,8	1,55	1,3	Weight kg





## serie B.121

Optional del freno: radiatore, ventilatore 24V, 110V, 220V, frizione  
 Brake optional: radiator, fan 24V, 110V, 220V, clutch

### B.121 freno/brake

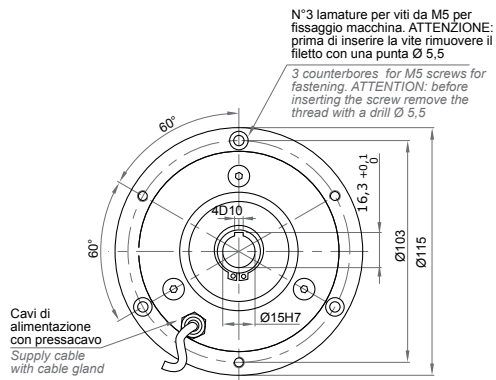

### B.121.R freno con radiatore brake with radiator

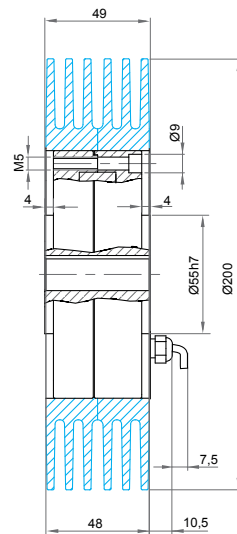

### B.121.V freno con ventilatore brake with fan

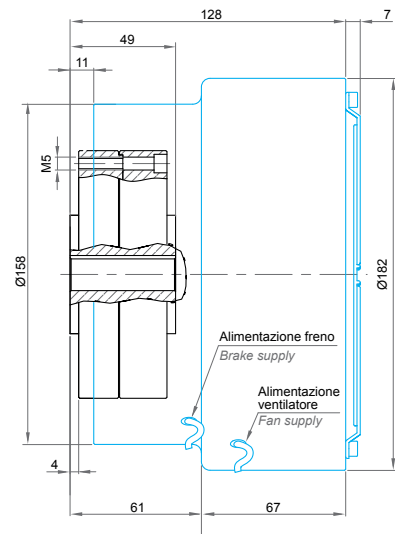

### C.121 frizione/clutch

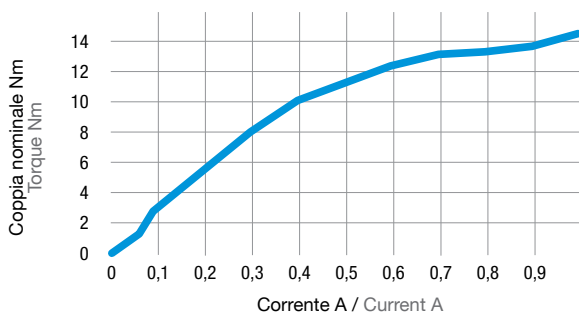
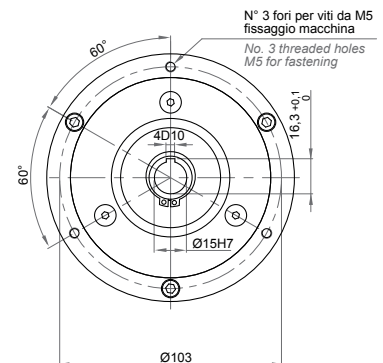
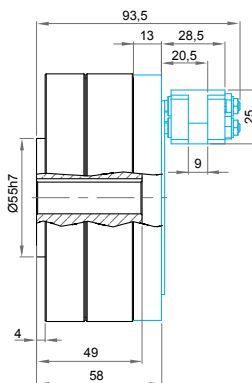
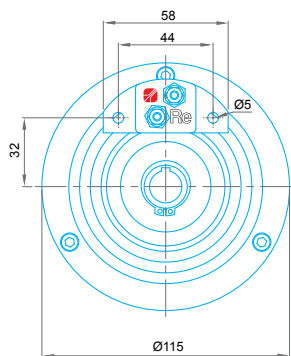

Per le versioni speciali (applicazioni a basso o alto numero di giri, ventilazione potenziata e asse verticale di applicazione) contattate il nostro ufficio tecnico. For the special versions (low or high rpm, enhanced fan and mounting on vertical axis) please contact our technical dpt.

Coppia nominale	12 Nm	Torque
Coppia residua	0,06 Nm	Residual torque
Corrente massima	1 A	Max current
Resistenza a 20°C	24 Ohm	Resistance at 20°C
Tensione	24 V (PWM)	Voltage
Potenza dissipabile B.121 con radiatore B.121.R con ventilatore B.121.V	80 W 160 W 350 W	Power dissipation B.121 with radiator B.121.R with fan B.121.V
C.121 a 500 rpm	140 W	C.121 at 500 rpm
C.121.R a 500 rpm	400 W	C.121.R at 500 rpm
C.121 a 1000 rpm	180 W	C.121 at 1000 rpm
C.121.R a 1000 rpm	560 W	C.121.R at 1000 rpm
Rpm min-max	40-2000	Rpm min-max
Max temp. esercizio	70°C	Max working temperature
Peso B.121	2,5 kg	Weight B.121
Peso B.121.R	4,5 kg	Weight B.121.R
Peso B.121.V	3,7 kg	Weight B.121.V
Peso C.121	3 kg	Weight C.121
Peso C.121.R	5 kg	Weight C.121.R





## serie B.351

Optional del freno: radiatore, ventilatore 24V, 110V, 220V, frizione  
Brake optional: radiator, fan 24V, 110V, 220V, clutch

### B.351 freno/brake

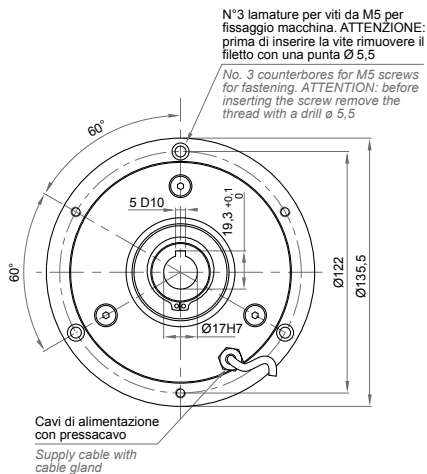

### B.351.R freno con radiatore brake with radiator

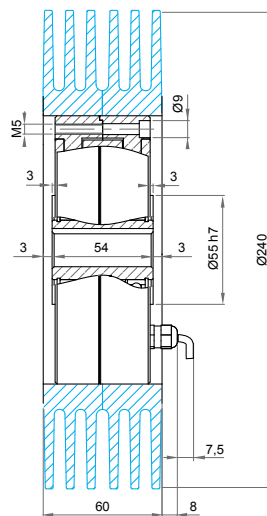

### B.351.V freno con ventilatore brake with fan

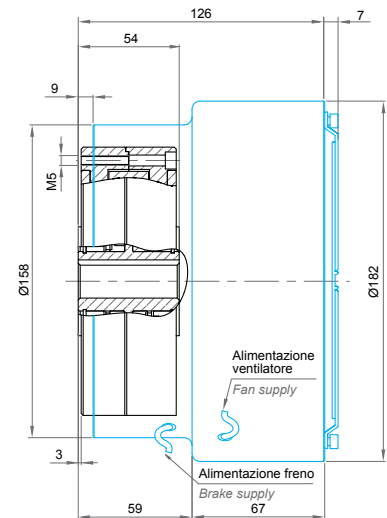

### C.351 frizione/clutch

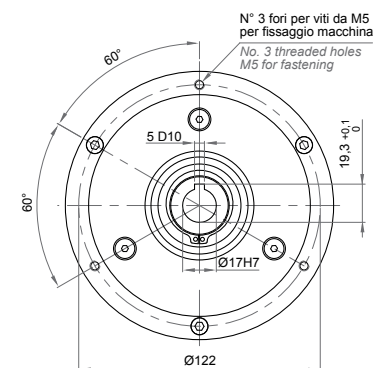
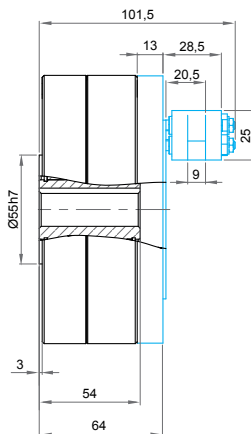
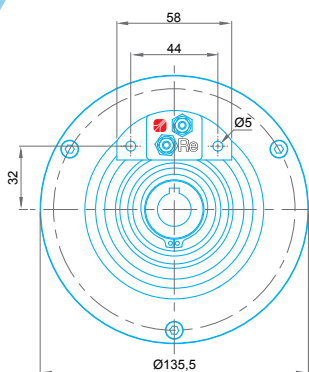

Coppia nominale	<b>35 Nm</b>	Torque
Coppia residua	<b>0,2 Nm</b>	Residual torque
Corrente massima	<b>1 A</b>	Max current
Resistenza a 20°C	<b>24 Ohm</b>	Resistance at 20°C
Tensione	<b>24 V (PWM)</b>	Voltage
Potenza dissipabile <b>B.351</b> con radiatore <b>B.351.R</b> con ventilatore <b>B.351.V</b>	<b>130 W</b> <b>230 W</b> <b>500 W</b>	Power dissipation <b>B.351</b> with radiator <b>B.351.R</b> with fan <b>B.351.V</b>
<b>C.351</b> a 500 rpm	<b>208 W</b>	<b>C.351</b> at 500 rpm
<b>C.351.R</b> a 500 rpm	<b>650 W</b>	<b>C.351.R</b> at 500 rpm
<b>C.351</b> a 1000 rpm	<b>260 W</b>	<b>C.351</b> at 1000 rpm
<b>C.351.R</b> a 1000 rpm	<b>810 W</b>	<b>C.351.R</b> at 1000 rpm
Rpm min-max	<b>40-2000</b>	Rpm min-max
Max temp. esercizio	<b>70°C</b>	Max working temperature
Peso <b>B.351</b>	<b>4 kg</b>	Weight <b>B.351</b>
Peso <b>B.351.R</b>	<b>7 kg</b>	Weight <b>B.351.R</b>
Peso <b>B.351.V</b>	<b>5,2 kg</b>	Weight <b>B.351.V</b>
Peso <b>C.351</b>	<b>4,6 kg</b>	Weight <b>C.351</b>
Peso <b>C.351.R</b>	<b>7,6 kg</b>	Weight <b>C.351.R</b>

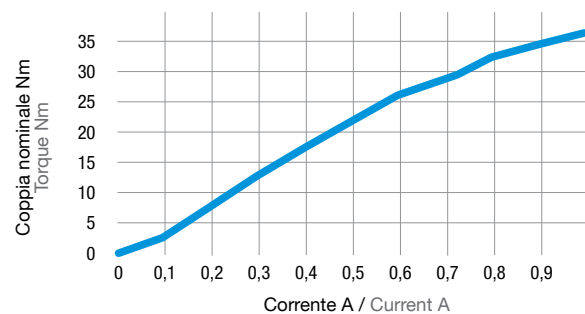

Per le versioni speciali (applicazioni a basso o alto numero di giri, ventilazione potenziata e asse verticale di applicazione) contattate il nostro ufficio tecnico. For the special versions (low or high rpm, enhanced fan and mounting on vertical axis) please contact our technical dept.

# serie B.651

Optional del freno: radiatore, ventilatore 24V, 110V, 220V, frizione  
 Brake optional: radiator, fan 24V, 110V, 220V, clutch

## B.651 freno/brake

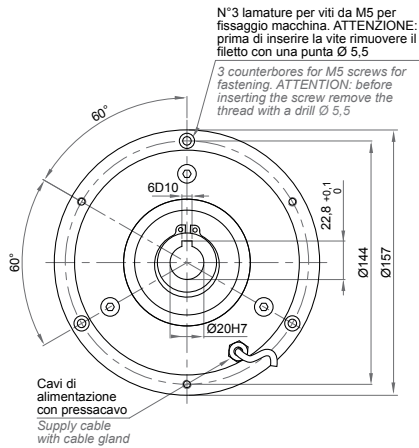

## B.651.R freno con radiatore brake with radiator

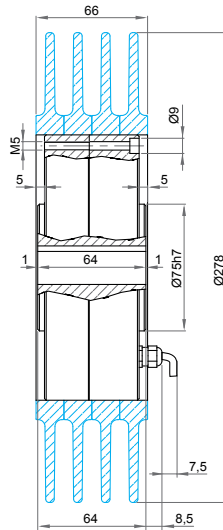

## B.651.V freno con ventilatore brake with fan

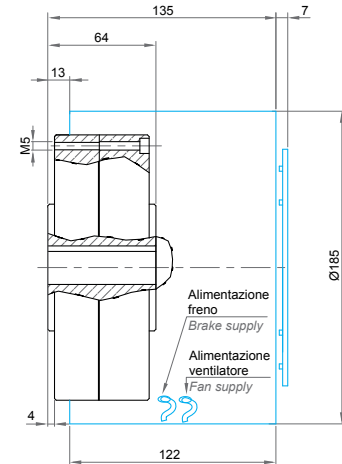

## C.651 frizione/clutch

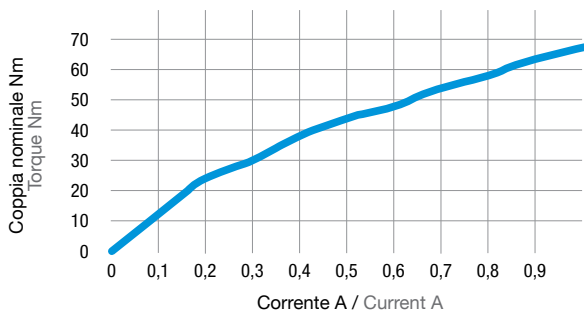
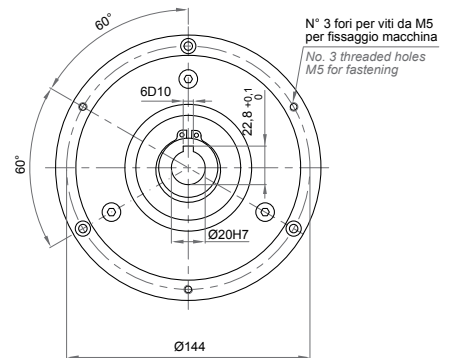
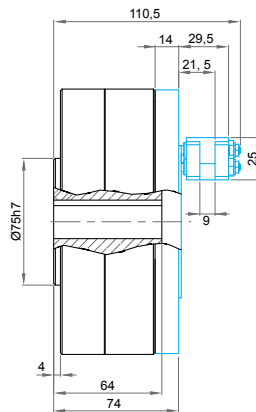
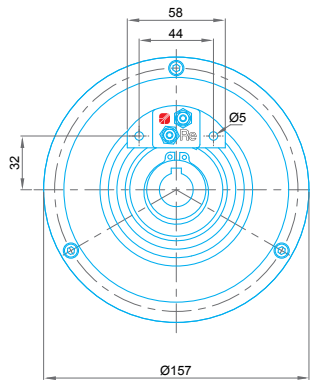

Per le versioni speciali (applicazioni a basso o alto numero di giri, ventilazione potenziata e asse verticale di applicazione) contattate il nostro ufficio tecnico. For the special versions (low or high rpm, enhanced fan and mounting on vertical axis) please contact our technical dept.

Coppia nominale	<b>65 Nm</b>	Torque
Coppia residua	<b>0,4 Nm</b>	Residual torque
Corrente massima	<b>1 A</b>	Max current
Resistenza a 20°C	<b>24 Ohm</b>	Resistance at 20°C
Tensione	<b>24 V (PWM)</b>	Voltage
Potenza dissipabile <b>B.651</b> con radiatore <b>B.651.R</b> con ventilatore <b>B.651.V</b>	<b>170 W</b> <b>400 W</b> <b>800 W</b>	Power dissipation <b>B.651</b> with radiator <b>B.651.R</b> with fan <b>B.651.V</b>
<b>C.651</b> a 500 rpm	<b>280 W</b>	<b>C.651</b> at 500 rpm
<b>C.651.R</b> a 500 rpm	<b>950 W</b>	<b>C.651.R</b> at 500 rpm
<b>C.651</b> a 1000 rpm	<b>350 W</b>	<b>C.651</b> at 1000 rpm
<b>C.651.R</b> a 1000 rpm	<b>1200 W</b>	<b>C.651.R</b> at 1000 rpm
Rpm min-max	<b>40-2000</b>	Rpm min-max
Max temp. esercizio	<b>70°C</b>	Max working temperature
Peso <b>B.651</b>	<b>6,5 kg</b>	Weight <b>B.651</b>
Peso <b>B.651.R</b>	<b>9 kg</b>	Weight <b>B.651.R</b>
Peso <b>B.651.V</b>	<b>8,8 kg</b>	Weight <b>B.651.V</b>
Peso <b>C.651</b>	<b>9,4 kg</b>	Weight <b>C.651</b>
Peso <b>C.651.R</b>	<b>9,4 kg</b>	Weight <b>C.651.R</b>



## serie B.1201

Optional del freno: radiatore, ventilatore 24V, 110V, 220V, frizione  
Brake optional: radiator, fan 24V, 110V, 220V, clutch

### B.1201 freno/brake

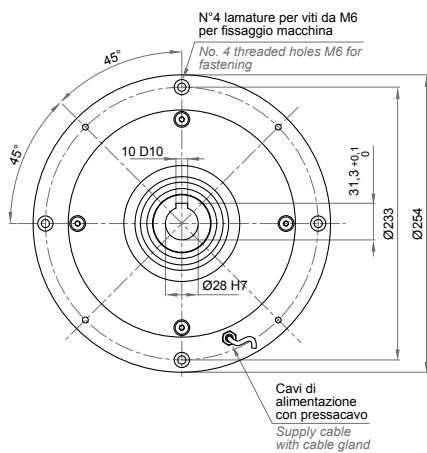

### B.1201.R freno con radiatore brake with radiator

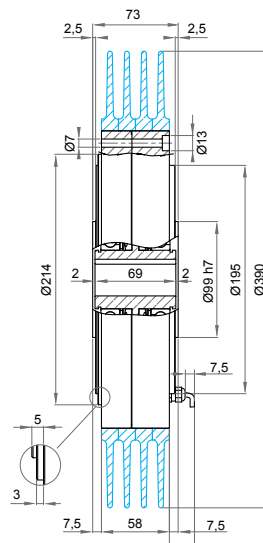

### B.1201.V freno con ventilatore brake with fan

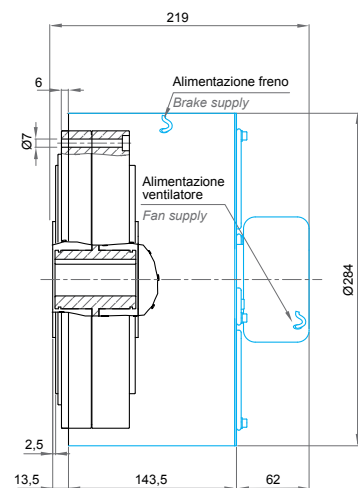

### C.1201 frizione/clutch

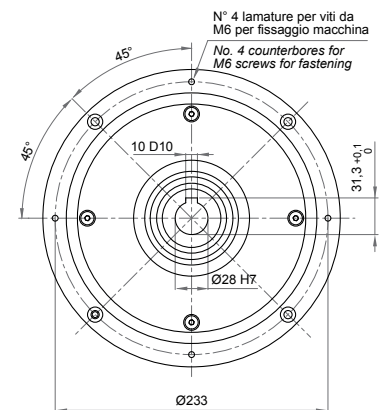
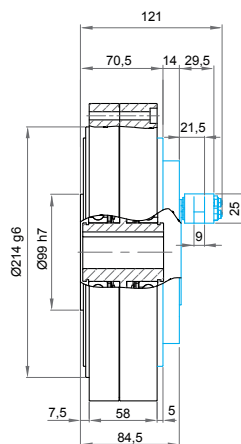
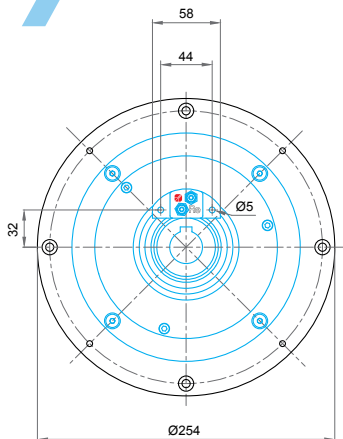

Coppia nominale	<b>120 Nm</b>	Torque
Coppia residua	<b>0,5 Nm</b>	Residual torque
Corrente massima	<b>1 A</b>	Max current
Resistenza a 20°C	<b>24 Ohm</b>	Resistance at 20°C
Tensione	<b>24 V (PWM)</b>	Voltage
Potenza dissipabile <b>B.1201</b>	<b>330 W</b>	Power dissipation <b>B.1201</b>
con radiatore <b>B.1201.R</b>	<b>650 W</b>	with radiator <b>B.1201.R</b>
con ventilatore <b>B.1201.V</b>	<b>1500 W</b>	with fan <b>B.1201.V</b>
<b>C.1201</b> a 500 rpm	<b>650 W</b>	<b>C.1201</b> at 500 rpm
<b>C.1201.R</b> a 500 rpm	<b>1440 W</b>	<b>C.1201.R</b> at 500 rpm
<b>C.1201</b> a 1000 rpm	<b>820 W</b>	<b>C.1201</b> at 1000 rpm
<b>C.1201.R</b> a 1000 rpm	<b>1800 W</b>	<b>C.1201.R</b> at 1000 rpm
Rpm min-max	<b>40-2000</b>	Rpm min-max
Max temp. esercizio	<b>70°C</b>	Max working temperature
Peso <b>B.1201</b>	<b>16,5 kg</b>	Weight <b>B.1201</b>
Peso <b>B.1201.R</b>	<b>19 kg</b>	Weight <b>B.1201.R</b>
Peso <b>B.1201.V</b>	<b>19 kg</b>	Weight <b>B.1201.V</b>
Peso <b>C.1201</b>	<b>17 kg</b>	Weight <b>C.1201</b>
Peso <b>C.1201.R</b>	<b>19,5 kg</b>	Weight <b>C.1201.R</b>

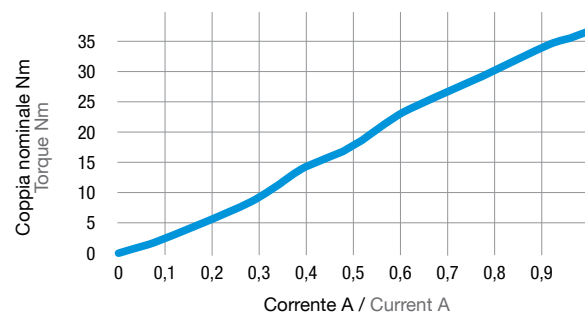

Per le versioni speciali (applicazioni a basso o alto numero di giri, ventilazione potenziata e asse verticale di applicazione) contattate il nostro ufficio tecnico. For the special versions (low or high rpm, enhanced fan and mounting on vertical axis) please contact our technical dpt.

# serie B.1701

Optional del freno: radiatore, ventilatore 24V, 110V, 220V, frizione  
 Brake optional: radiator, fan 24V, 110V, 220V, clutch

## B.1701 freno/brake

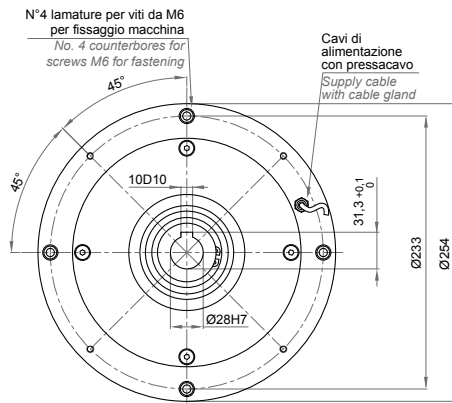

## B.1701.R freno con radiatore brake with radiator

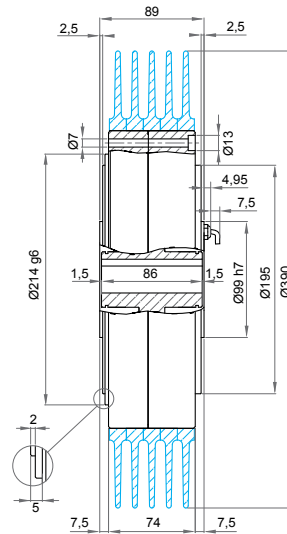

## B.1701.V freno con ventilatore brake with fan

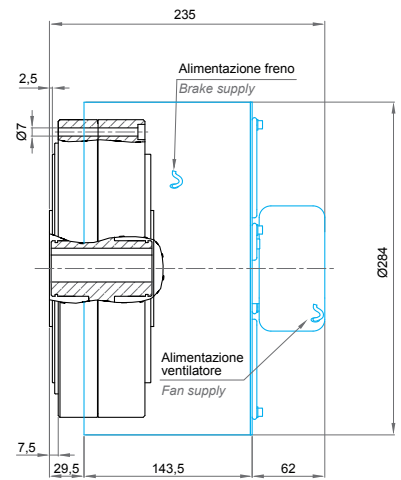

## C.1701 frizione/clutch

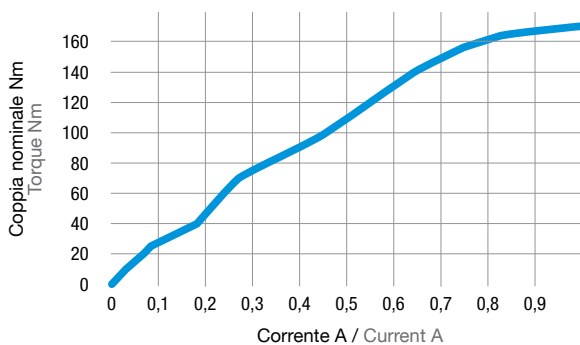
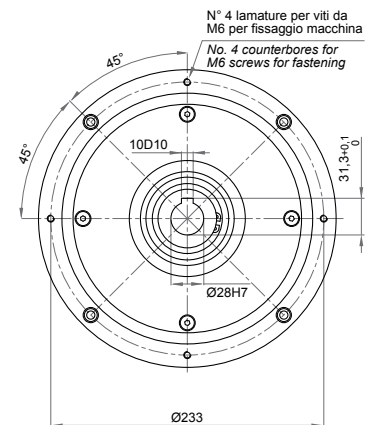
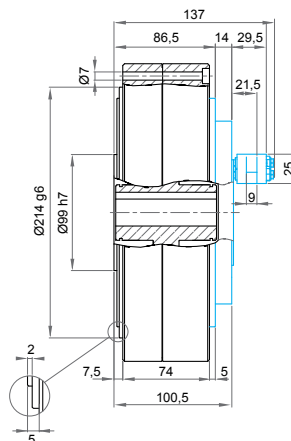
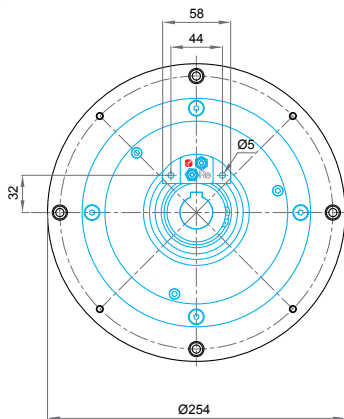

Per le versioni speciali (applicazioni a basso o alto numero di giri, ventilazioni potenziata e asse verticale di applicazione) contattate il nostro ufficio tecnico. For the special versions (low or high rpm, enhanced fan and mounting on vertical axis) please contact our technical dpt.

Coppia nominale	170 Nm	Torque
Coppia residua	0,5 Nm	Residual torque
Corrente massima	1 A	Max current
Resistenza a 20°C	24 Ohm	Resistance at 20°C
Tensione	24 V (PWM)	Voltage
Potenza dissipabile B.1701 con radiatore B.1701.R	450 W	Power dissipation B.1701 with radiator B.1701.R
con ventilatore B.1701.V	850 W	with fan B.1701.V
C.1701 a 500 rpm	1600 W	C.1701 at 500 rpm
C.1701.R a 500 rpm	760 W	C.1701.R at 500 rpm
C.1701 a 1000 rpm	1550 W	C.1701 at 1000 rpm
C.1701.R a 1000 rpm	950 W	C.1701.R at 1000 rpm
Rpm min-max	40-2000	Rpm min-max
Max temp. esercizio	70°C	Max working temperature
Peso B.1701	22,5 kg	Weight B.1701
Peso B.1701.R	25,5 kg	Weight B.1701.R
Peso B.1701.V	25 kg	Weight B.1701.V
Peso C.1701	22,9 kg	Weight C.1701
Peso C.1701.R	26 kg	Weight C.1701.R





## serie B.2500

Optional del freno: radiatore, ventilatore 24V, 110V, 220V, frizione  
Brake optional: radiator, fan 24V, 110V, 220V, clutch

### B.2500 freno/brake

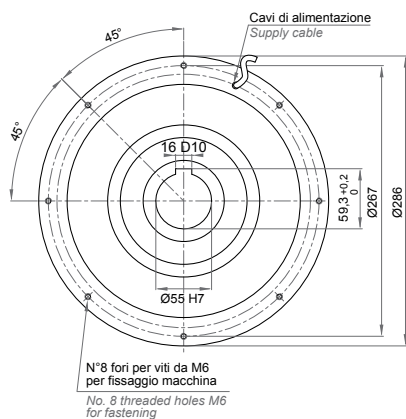

### B.2500.R freno con radiatore brake with radiator

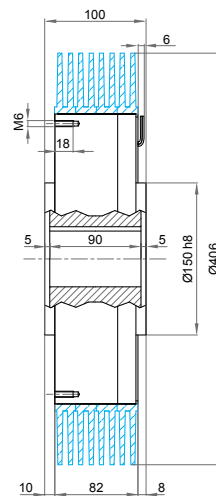

### B.2500.V freno con ventilatore brake with fan

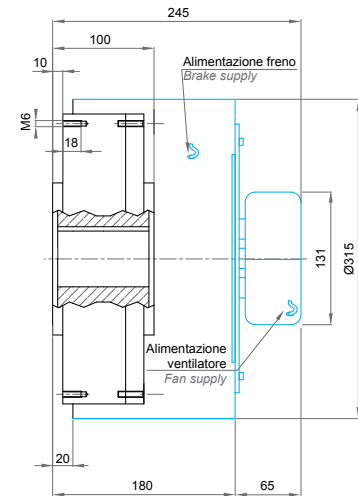

### C.2500 frizione/clutch

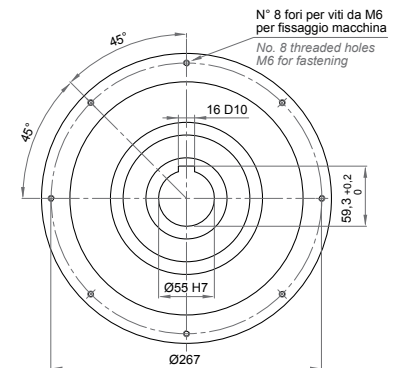
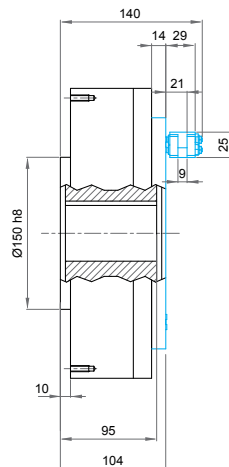
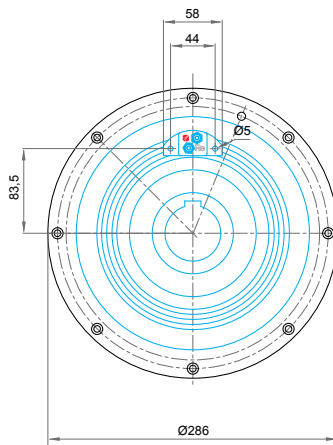

Coppia nominale	<b>250 Nm</b>	Torque
Coppia residua	<b>3 Nm</b>	Residual torque
Corrente massima	<b>0,94 A</b>	Max current
Resistenza a 20°C	<b>25,5 Ohm</b>	Resistance at 20°C
Tensione	<b>24 V (PWM)</b>	Voltage
Potenza dissipabile <b>B.2500</b> con radiatore <b>B.2500.R</b> con ventilatore <b>B.2500.V</b>	<b>500 W</b> <b>900 W</b> <b>2000 W</b>	Power dissipation <b>B.2500</b> with radiator <b>B.2500.R</b> with fan <b>B.2500.V</b>
<b>C.2500</b> a 500 rpm	<b>1440 W</b>	<b>C.2500</b> at 500 rpm
<b>C.2500.R</b> a 500 rpm	<b>1650 W</b>	<b>C.2500.R</b> at 500 rpm
<b>C.2500</b> a 1000 rpm	<b>1800 W</b>	<b>C.2500</b> at 1000 rpm
<b>C.2500.R</b> a 1000 rpm	<b>2400 W</b>	<b>C.2500.R</b> at 1000 rpm
Rpm min-max	<b>40-1800</b>	Rpm min-max
Max temp. esercizio	<b>70°C</b>	Max working temperature
Peso <b>B.2500</b>	<b>32 kg</b>	Weight <b>B.2500</b>
Peso <b>B.2500.R</b>	<b>38 kg</b>	Weight <b>B.2500.R</b>
Peso <b>B.2500.V</b>	<b>38 kg</b>	Weight <b>B.2500.V</b>
Peso <b>C.2500</b>	<b>33 kg</b>	Weight <b>C.2500</b>
Peso <b>C.2500.R</b>	<b>40 kg</b>	Weight <b>C.2500.R</b>

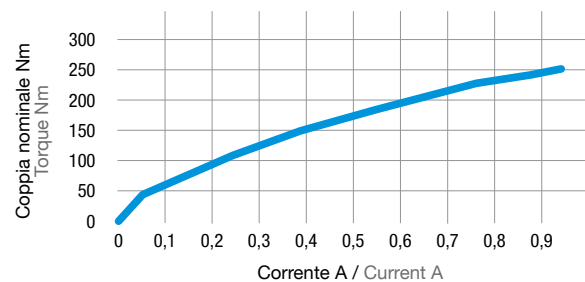

Per le versioni speciali (applicazioni a basso o alto numero di giri, ventilazione potenziata e asse verticale di applicazione) contattate il nostro ufficio tecnico. For the special versions (low or high rpm, enhanced fan and mounting on vertical axis) please contact our technical dept.

# serie B.5000

Optional del freno: radiatore, ventilatore 24V, 110V, 220V, frizione  
 Brake optional: radiator, fan 24V, 110V, 220V, clutch

## B.5000 freno/brake

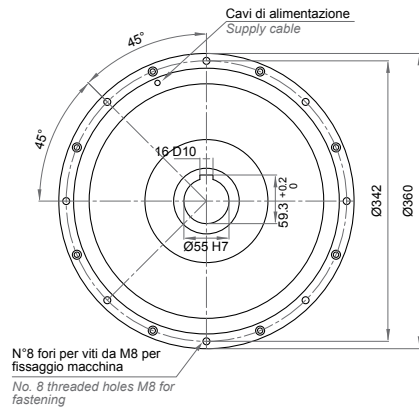

## B.5000.R freno con radiatore brake with radiator

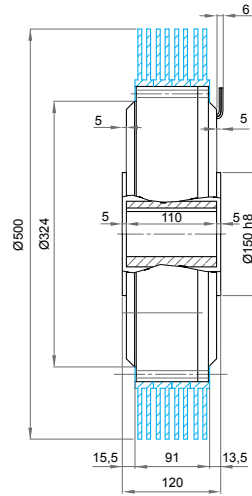

## B.5000.V freno con ventilatore brake with fan

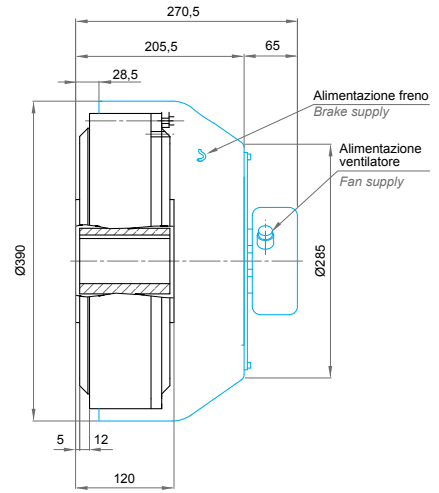

## C.5000 frizione/clutch

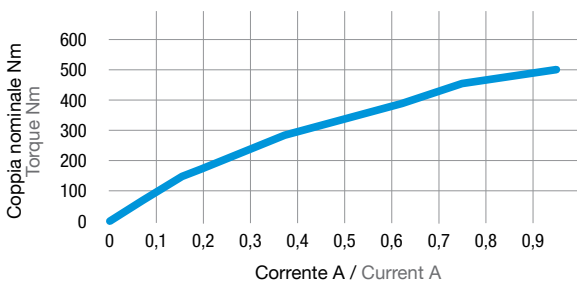
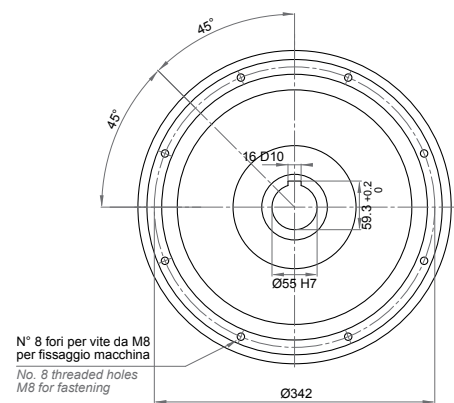
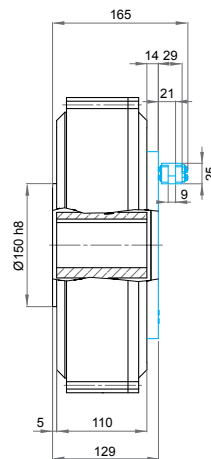
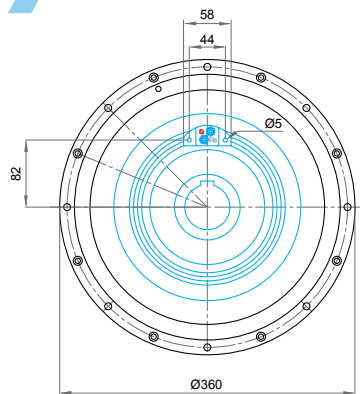

Per le versioni speciali (applicazioni a basso o alto numero di giri, ventilazione potenziata e asse verticale di applicazione) contattate il nostro ufficio tecnico. For the special versions (low or high rpm, enhanced fan and mounting on vertical axis) please contact our technical dpt.

Coppia nominale	<b>500 Nm</b>	Torque
Coppia residua	<b>6 Nm</b>	Residual torque
Corrente massima	<b>0,94 A</b>	Max current
Resistenza a 20°C	<b>25,5 Ohm</b>	Resistance at 20°C
Tensione	<b>24 V (PWM)</b>	Voltage
Potenza dissipabile B.5000 con radiatore B.5000.R	<b>1300 W</b>	Power dissipation B.5000 with radiator B.5000.R
con ventilatore B.5000.V	<b>2500 W</b>	with fan B.5000.V
C.5000 a 500 rpm	<b>4000 W</b>	C.5000 at 500 rpm
C.5000.R a 500 rpm	<b>2800 W</b>	C.5000.R at 500 rpm
C.5000 a 1000 rpm	<b>4000 W</b>	C.5000 at 1000 rpm
C.5000.R a 1000 rpm	<b>3500 W</b>	C.5000.R at 1000 rpm
Rpm min-max	<b>40-1500</b>	Rpm min-max
Max temp. esercizio	<b>70°C</b>	Max working temperature
Peso B.5000	<b>59 kg</b>	Weight B.5000
Peso B.5000.R	<b>62 kg</b>	Weight B.5000.R
Peso B.5000.V	<b>62 kg</b>	Weight B.5000.V
Peso C.5000	<b>62 kg</b>	Weight C.5000
Peso C.5000.R	<b>65 kg</b>	Weight C.5000.R



## Parti di ricambio Spare parts

Alcune parti di ricambio per la sostituzione della polvere magnetica.  
Spare parts for replacing the magnetic powder.

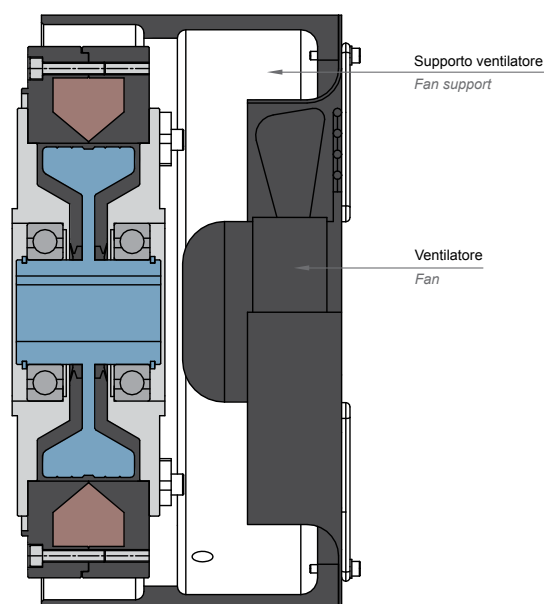
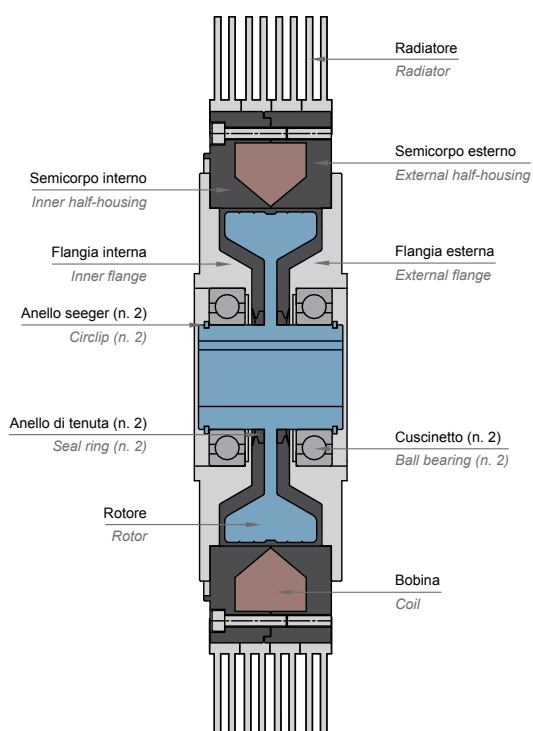



## FP.25

### Regolatore di corrente per freni elettromagnetici a polvere

La scheda FP.25 è un regolatore di corrente analogico che permette di fornire la giusta intensità di corrente al freno o alla frizione a polvere elettromagnetica.

La regolazione ad anello chiuso di corrente garantisce stabilità della coppia indipendentemente dalle variazioni della tensione e della temperatura del freno/frizione e dell'ambiente circostante. La possibilità di inserire l'azione derivativa permette di gestire anche sistemi a ballerino.

Il collegamento della scheda è semplice grazie ad un connettore volante a 10 poli con bloccaggio a vite dei terminali.

### Current regulator for electromagnetic powder brakes

The FP.25 board is an analogue current regulator that ensures the current supplied to the electromagnetic powder brake or clutch is at the correct level.

It is possible to use a closed current loop in order to guarantee that the torque remains stable, irrespective of variations in the supply voltage or the brake/clutch and ambient temperatures. The derivative parameter permits to use a dancing roller system. To simplify the installation procedure, the board is equipped with a 10 poles, screw locking connector.

FP.25/1  
scheda/card

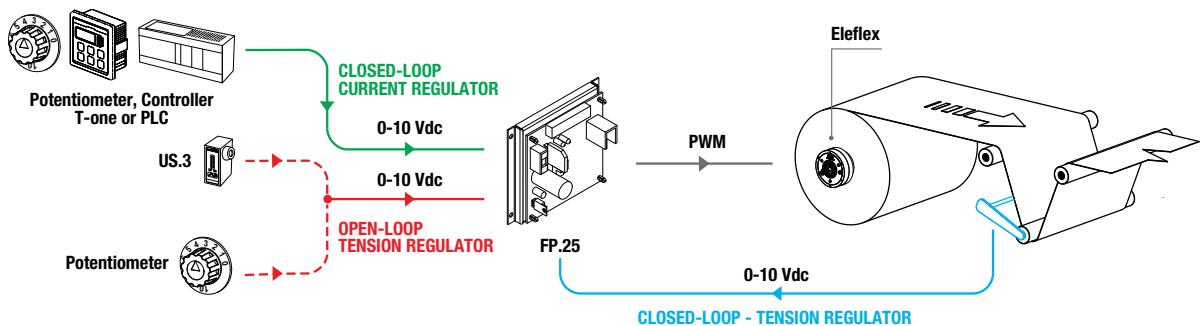

Alimentazione FP.25/1	24 Vdc (± 10%)	FP.25/1 Voltage supply
Alimentazione FP.25/2	110/220 Vac - 50/60 Hz - Fuse 3,15 A/T	FP.25/2 Voltage supply
Potenza	30 W max	Power
Ingresso	0-10 Vdc	Input
Uscita	0-2 PWM	Output
Limitatore di corrente	TR1 da -50% a +50% TR1 from -50% to +50%	Current limiter
Polarizzazione	TR2 da 0% a 100% TR2 from 0% to 100%	Polarization
Temperatura di lavoro	0±50° C	Working temperature
Dimensione	63 x 120 x 108 mm	Dimensions





## Leo

### Regolatore di corrente per freni elettromagnetici a polvere

Leo è un regolatore di corrente digitale a microprocessore la cui programmazione è eseguibile tramite i tre tasti presenti sul pannello dello strumento. La sua versatilità permette diverse modalità di lavoro:

- Modalità standard: in sistemi a loop-chiuso come regolatore di corrente abbinato ad un regolatore di tiro (T-one, T-two, PLC)
- Modalità regolatore:
  - in sistemi a loop-aperto come controllo di tiro abbinato a sonar (servodiametro) o potenziometro;
  - in sistemi a loop-chiuso come controllo di tiro di tipo proporzionale-derivativo, con ballerino e potenziometro.

La scheda Leo mantiene stabile la coppia applicata al freno/frizione indipendentemente dalle variazioni delle caratteristiche del freno grazie al suo loop di corrente interna. Lo strumento è inoltre in grado di annullare il magnetismo residuo (funzione Antiresidual) così da operare nel campo delle basse coppie. Applicabile su barra DIN Leo è stato studiato appositamente per occupare il minimo ingombro garantendo massima efficienza.

### Current regulator for electromagnetic powder brakes

Leo is a microprocessor controlled digital current regulator that can be programmed by using the three buttons on the device panel.

- Leo's flexibility allows many different uses:
- Standard working method: in closed-loop as current regulator combined with a tension controller (t-one, T-two, PLC)
  - Tension controller working method:
    - in open-loop systems as a tension controller combined with a sonar (servodiameter) or potentiometer;
    - in closed-loop as a tension controller proportional-derivative, with dancing roller and potentiometer.

Leo guarantees brake/clutch torque stability irrespective of variations in the condition of the brake thanks to its internal current loop. The device can also cancel any residual magnetism (Antiresidual function) making it suitable for use in low torque applications without limitations. Small enough to be mounted on DIN guides Leo has been designed to take up the minimum amount of space while ensuring efficiency.

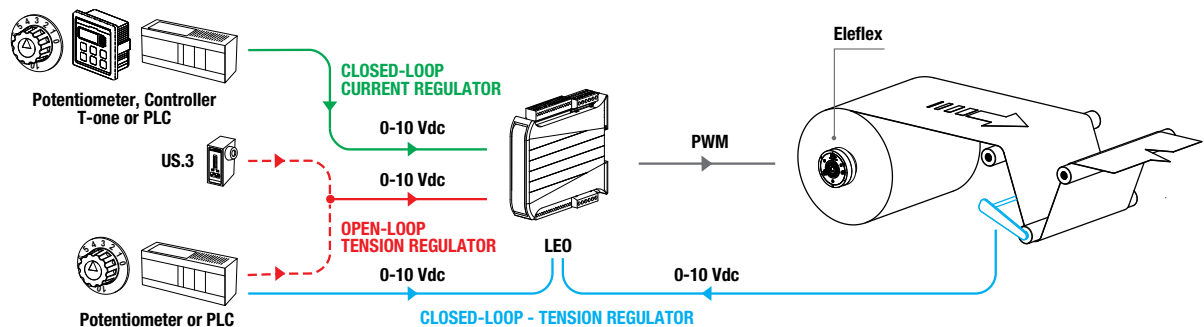

Alimentazione	<b>24 Vdc (± 10%) - FUSE 3,15 A/T</b>	Voltage supply
Potenza	<b>35 W max</b>	Power
Ingresso analogico 0÷10 Vdc	<b>1 comando freno o pot. ballerino brake control or dancing roller pot.</b>	Analog input 0÷10 Vdc
Ingressi digitali 24 Vdc	<b>1 sblocco freno (zero) / brake unlock (zero) 1 arresto prioritario / priority stop</b>	Digital inputs 24 Vdc
Uscita 10 Vdc	<b>1 alimentazione potenziometri potentiometer supply</b>	Output 10 Vdc
Uscita PWM -1÷1 A	<b>1 freno elettromagnetico electromagnetic brake</b>	PWM output -1÷1 A
Temperatura di lavoro	<b>0÷50° C</b>	Working temperature
Grado di protezione IP	<b>IP20</b>	IP protection class
Dimensioni	<b>22,5 x 101 x 119 mm</b>	Dimensions



**FP.25/1**

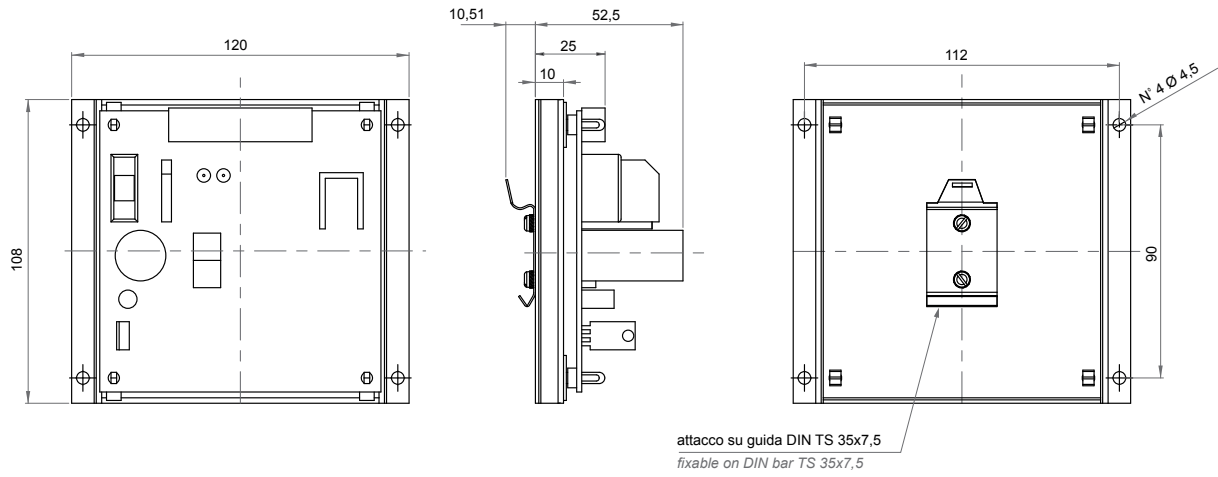

**FP.25/2**

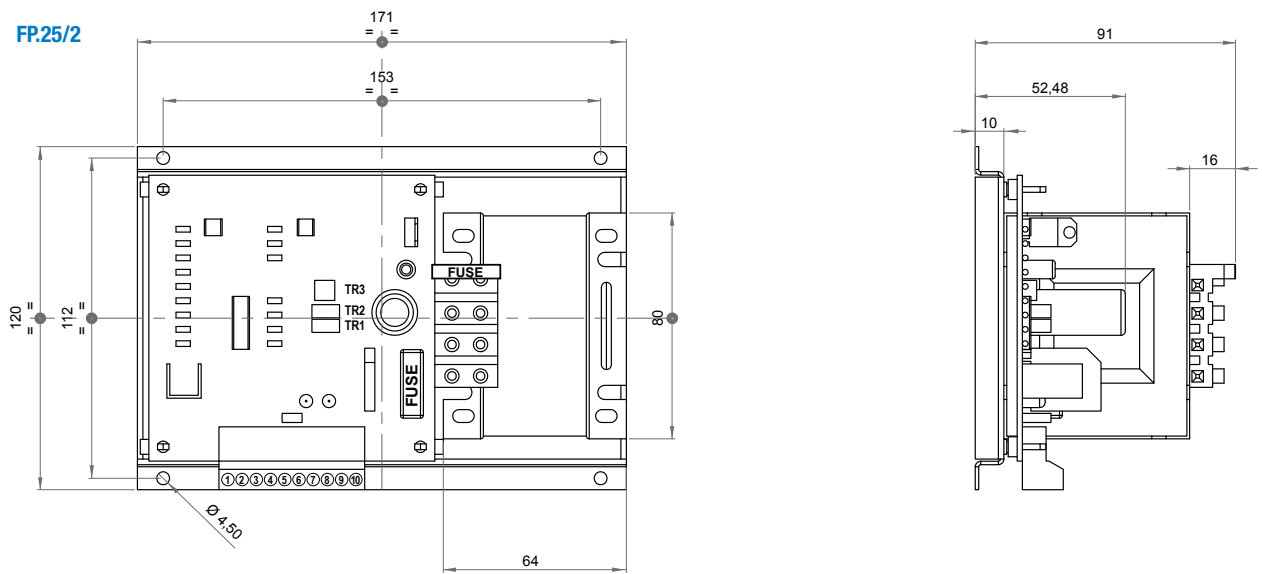

**LEO**

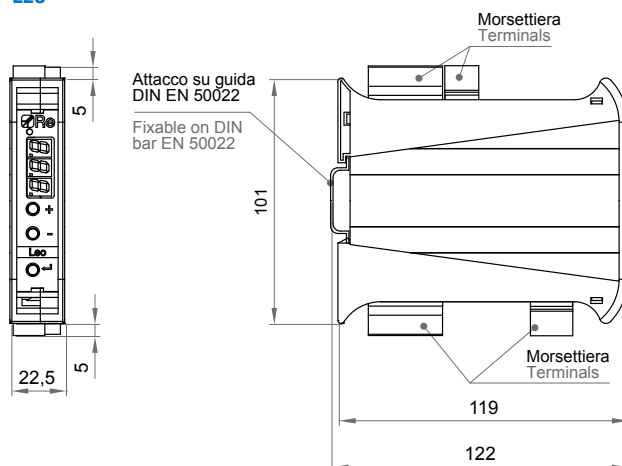

Azienda/Company	Contatto/Contact
Città/City	Nazione/Country
Tel	E-mail

Tipo di macchina da stampa: / Printing press-type: \_\_\_\_\_

Tipo di nastro/Type of web

<input type="checkbox"/> Carta/Paper	<input type="checkbox"/> Cartone/Cardboard	<input type="checkbox"/> Film
<input type="checkbox"/> Film trasparente/Transparent film	<input type="checkbox"/> Alluminio/Aluminium	<input type="checkbox"/> Altro/Other

Max temperatura ambientale/Max ambient temperature \_\_\_\_\_ °C

Zona antideflagrante/Explosion proof area

**Dati richiesti/Data required**

Diametro max bobina/Max roll diameter (D): \_\_\_\_\_ m

Diametro min bobina/Min roll diameter (d): \_\_\_\_\_ m

Larghezza max bobina/Max roll width (Lg<sub>max</sub>): \_\_\_\_\_ cm

Larghezza min bobina/Min roll width (Lg<sub>min</sub>): \_\_\_\_\_ cm

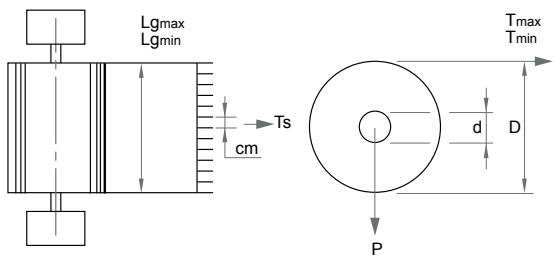

**Tipo di materiale da lavorare/Type of material**

Peso del materiale/Weight of the material: \_\_\_\_\_ g/m<sup>2</sup>

Spessore del materiale/Thickness of the material: \_\_\_\_\_ µm

Velocità lineare nominale (V)/Nominal linear speed: \_\_\_\_\_ m/min

Tempo di arresto in emergenza/Emergency stop time (t): \_\_\_\_\_ s (seconds)

Peso massimo bobina/Max roll weight: \_\_\_\_\_ Kg

**Applicazione/Application**

1 freno per bobina/1 brake for roll

2 freni per bobina/2 brakes for roll

Frizione/Clutch

**Dettagli albero/Drive shaft details:**

Lunghezza perno/Drive shaft length (A): \_\_\_\_\_ mm

Ø Diametro perno/Drive shaft diameter (B): \_\_\_\_\_ mm

Distanza tra fine del perno e fine della chiavetta  
 Distance between end of driveshaft and keyway (C): \_\_\_\_\_ mm

Lunghezza chiavetta/Keyway length (D): \_\_\_\_\_ mm

Altezza chiavetta/Keyway height (E): \_\_\_\_\_ mm

Profondità chiavetta/Keyway depth (F): \_\_\_\_\_ mm

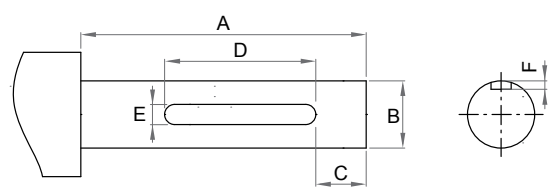

**Applicazione freno**  
*Brake application*

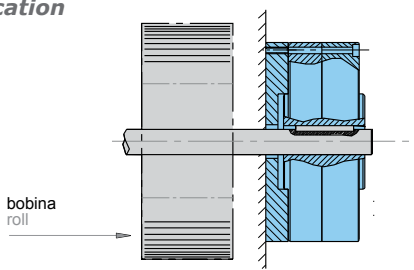

**Applicazione frizione**  
*Clutch application*

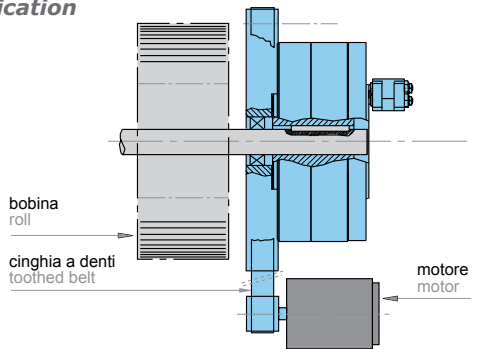

[www.re-spa.com](http://www.re-spa.com)